



# INTER•PAK SERIES SC-200 Stationary Compactor

See for yourself how we crush the competition!



## FEATURES & SPECS



### CHARGE BOX

CYCLE TIME: EXT: 40 SEC REC: 35 SEC  
OPENING: 41" L X 60" W  
SIDES: 3/16" THICK WITH STRUCTURAL SUPPORTS  
FLOOR: 3/8" THICK PLATE WITH 4" CHANNEL CROSSMEMBERS  
BREAKER BAR: 6" X 8" X 1"

### RAM

FACE PLATE: 3/8" THICK WITH 6" CHANNEL CROSSMEMBERS  
BOTTOM: 3/8" THICK  
SIDES: 1/4" THICK  
TOP: 1/4" THICK WITH 4" CHANNELS  
GUIDES: REPLACEABLE 3 POINT NYLATRON GUIDES  
PENETRATION: 15"  
NORMAL FORCE: 50,800 LBS MAX FORCE: 56,500 LBS  
RAM FACE PRESSURE: NORMAL: 29.9PSI MAX: 33.2 PSI

### ELECTRICAL

MOTOR: 10 HP 3/60-208/230/460 VAC  
CONTROL VOLTAGE: 120 VAC  
15' REMOTE PENDANT WITH 4 BUTTON STATION  
15' REMOTE COLOR-CODED PRESSURE GAUGE  
KEY AUTO/HAND, EMERGENCY STOP WITH LIGHT, START, FOR/REV  
100% LIGHT, 15' POWER PIG TAIL

## INTER-PAK SERIES SC-200 Stationary Compactor

### HYDRAULIC

RESERVOIR CAPACITY: 28 GALLONS

PUMP: 10.5 GPM

NORMAL PRESSURE: 1800 PSI MAX PRESSURE: 2000 PSI

HYDRAULIC CYLINDER:

BORE: 6" ROD: 2.5" STROKE: 56"

### AVAILABLE OPTIONS

PREMIUM POWER UNIT

80% FULL LIGHT

HEAVY DUTY CYLINDER

OIL TANK HEATER

DOOR COUNTER SYSTEM

LOW TEMPERATURE OIL

MONITORING SYSTEM

PHOTO ELECTRIC EYE

DOG HOUSES, ENCLOSURES

WALK ON DECK, DRIVE ON DECK

### COLORS



*\*Color Match Available*

FRONT VIEW

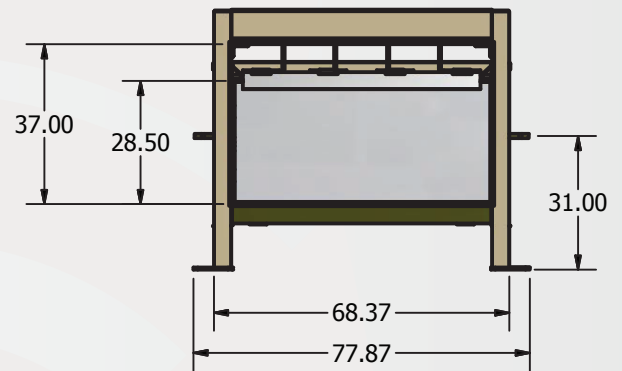

TOP VIEW

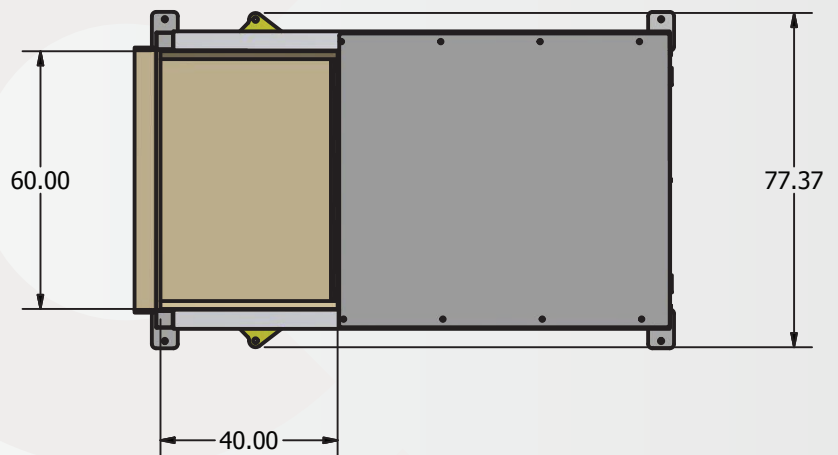

SIDE VIEW

